

TECHNICAL DATA SHEET

DDP 002R

Cross spacer for pavers 2 mm (1/16") rubber

BASIC INFORMATION

Product name	Cross spacer for pavers 2 mm (1/16") rubber
Trade name	DDP 002R
Product group	Support pads
Application	Terrace with tiles
Code	Tile gap 3 mm (1/8") - 10549 Tile gap 5 mm (3/16") - 10542

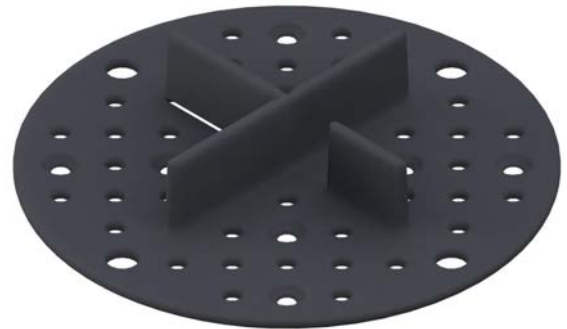

FEATURES

- Designed for pavers/tiles.
- Height of 2 mm (1/16").
- Prevents warping and shifting of tiles.
- Stabilizes corners and gaps between tiles.
- Resistant to heavy loads.

DESCRIPTION

Pads are used to place tiles on them in order to stabilize corners and gaps between tiles. They allow laying stable and even surface, preventing tile warping. They are used for direct placement on the substrate, indirectly on rubber pads or on other types of substrate / substructure. The pads have built-in vertical ribs with a width of 3 mm (1/8") for determining gaps between laid terrace elements. There is also the possibility of installing additional 5 mm (3/16") gap spacers (L5).

PARAMETERS

Height	2 mm (1/16")
Diameter	Ø 100 mm (78,5 cm ²) Ø 4" (12,56 in ²)
Width of the built-in tile gap	3 mm (1/8")
Weight	0,019 kg 0.042 lbs
Load resistance	up to 2500 kg up to 5500 lbs
Operating temperature	-20°C; +65°C -4°F; +149°F
Color	Black
Material	Rubber

APPLICATION

- Terrace with tiles.

CERTIFICATION

Up to date certificates and test reports available on demand:

1. Characteristic pedestal vertical load test.
2. Decrease of pedestal load bearing induced by laboratory UV light source exposure.
3. Decrease of pedestal load bearing capacity induced by thermal shock.
4. Decrease of pedestal load bearing capacity induced by salt water impact.
5. Decrease of pedestal load bearing capacity induced by temperature decrease -20°C / -4°F (24h).
6. Decrease of pedestal load bearing capacity induced by temperature increase to 65°C / +149°F (24h).
7. Characteristic value of deformation increase per unit of force induced by creep during 1000 hour test.
8. Reaction to fire classification, class.

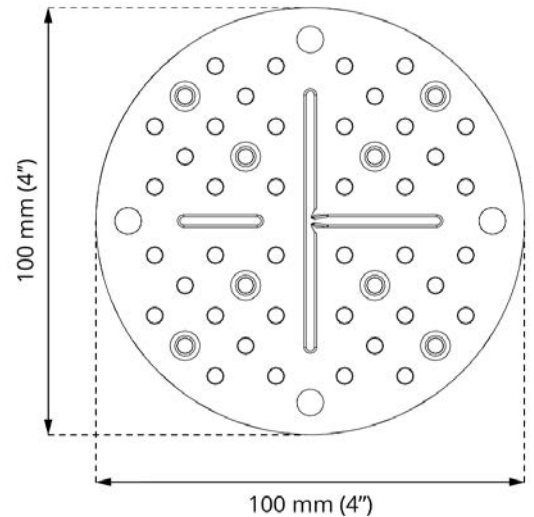
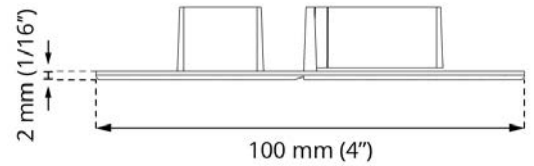

TILE GAP

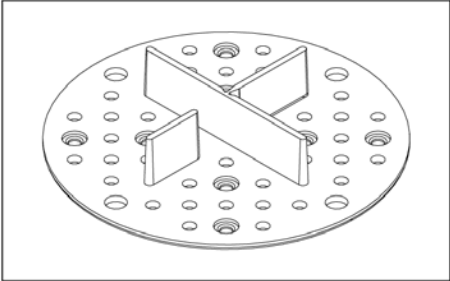
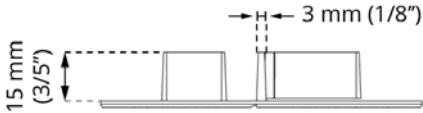
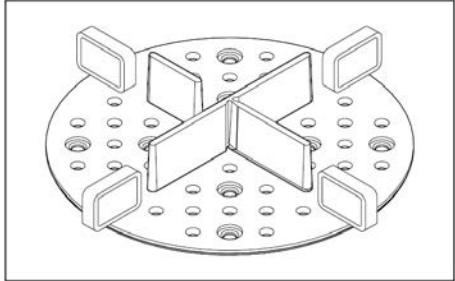
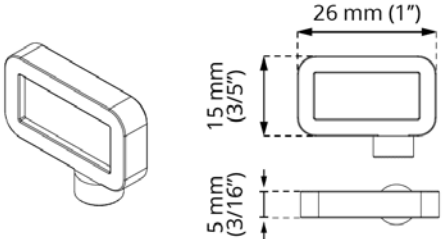
Basic	With a gap spacer 5 mm (3/16")
<p>DDP 002R - built-in gap spacer 3 mm (1/8")</p>  	<p>DDP 002R with gap spacer 5 mm (3/16") (L5)</p>  

USAGE

Designed for use with tiles, they allow laying stable and even surface, stabilizing corners and gaps between tiles. The pads can be easily trimmed/broken due to their modular construction - for convenience, lines are marked on the base that easily indicate sections to be trimmed/broken. The divided construction of the base and spacer allows for laying in any arrangement of tiles. For additional, stronger floor stabilization, the pads can be secured to the substrate using metal spikes.

DATA LOGISTICS

Product	Type	Size	Quantity	Weight brutto
DDP 002R	Carton box	60 x 50 x 20 cm (23 2/3" x 19 2/3" x 7 7/8")	350 pcs.	8,85 kg (19.51 lbs)
	Pallet	120 x 100 x 220 cm (47 1/4" x 39 1/2" x 86")	14000 pcs.	374 kg (824.53 lbs)

ADDITIONAL ACCESSORIES

Gap spacer 5 mm (3/16") **L5**, SBR rubber pad **SBR100/3**, SBR rubber pad **SBR100/8**.

EXAMPLE OF APPLICATION

