

TECHNICAL DATA SHEET

SPIRAL 070-090

Adjustable terrace pedestal SPIRAL 70-90 mm (2 3/4" - 3 1/2")

BASIC INFORMATION

Product name	Adjustable terrace pedestal SPIRAL 70-90 mm (2 3/4" - 3 1/2")
Trade name	SPIRAL 070-090
Product group	Adjustable pedestals - SPIRAL series
Application	Terrace with tiles Terrace with decking
Code	Tile gap 3 mm (1/8") - 104331 Tile gap 5 mm (3/16") - 10888 Joist version - 10890



FEATURES

- Height range from 70 to 90 mm (from 2 3/4" to 3 1/2").
- Step-height adjustment every 1 mm (1/32").
- Suitable for tiles and joists.
- Resistant to heavy loads.
- Can be used on a significantly sloping surface.

DESCRIPTION

Adjustable pedestals for raised terraces (so-called elevated) from the SPIRAL series allow for precise adjustment of terrace height in the range of 10 to 210 mm (6/16" to 8 1/3"). Their unique step construction allows for adjustment every 1 mm (1/32") and ensures high load-bearing capacity. Thanks to the SPIRAL series, it is possible to adjust terrace height starting from the lowest height of 10 mm (6/16"). Additionally, there is a possibility to expand the functionality of the supports with additional accessories. The use of a gap disk allows for the installation of terraces with pavers or tiles, while the joist adapter allows installation of joist and decking.

PARAMETERS

Minimum height	70 mm (2 3/4")
Maximum height	90 mm (3 1/2")
Height adjustment type	Step height adjustment (1 mm) (1/32")
Diameter	Ø 169 mm (224,3 cm ²) Ø 6 2/3" (34,77 in ²)
Weight	~ 0,333 kg ~ 0.734 lbs
Load resistance	up to 2400 kg up to 5290 lbs
Operating temperature	-20°C; +65°C -4°F; +149°F
Color	Black
Material	Certified plastic PP

APPLICATION

- Terrace with tiles (D3 or D5).
- Terrace with decking (DAD).

COMPONENTS

- Basic version of SPIRAL 070-090 is composed of 2 pieces:
BOTTOM 070-090 + TOP 070-090
- SPIRAL 070-090 tile gap 3 mm (1/8") version:
BOTTOM 070-090 + TOP 070-090 + D3
- SPIRAL 070-090 tile gap 5 mm (3/16") version:
BOTTOM 070-090 + TOP 070-090 + D5
- SPIRAL 070-090 decking version:
BOTTOM 070-090 + TOP 070-090 + DAD

CERTIFICATION

Up to date certificates and test reports available on demand:

1. Characteristic pedestal vertical load test.
2. Decrease of pedestal load bearing induced by laboratory UV light source exposure.
3. Decrease of pedestal load bearing capacity induced by thermal shock.
4. Decrease of pedestal load bearing capacity induced by salt water impact.
5. Decrease of pedestal load bearing capacity induced by temperature decrease -20°C / -4°F (24h).
6. Decrease of pedestal load bearing capacity induced by temperature increase to 65°C / +149°F (24h).

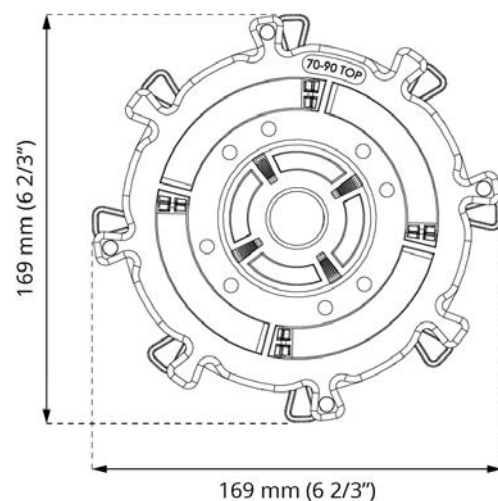
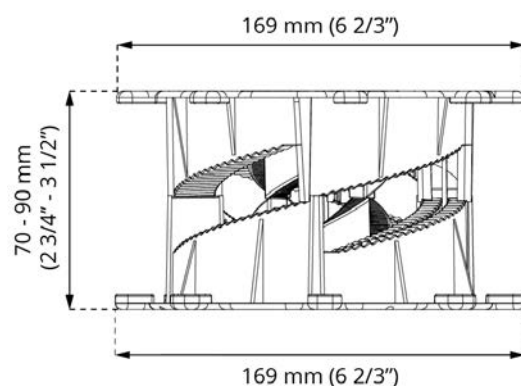

7. Characteristic value of deformation increase per unit of force induced by creep during 1000 hour test.
8. Reaction to fire classification, class.

PEDESTAL HEAD FINISHING ELEMENT

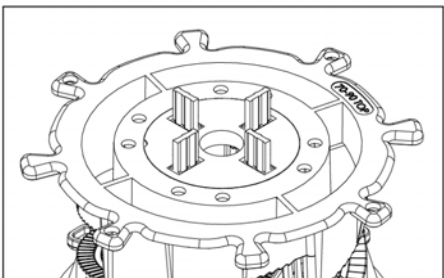
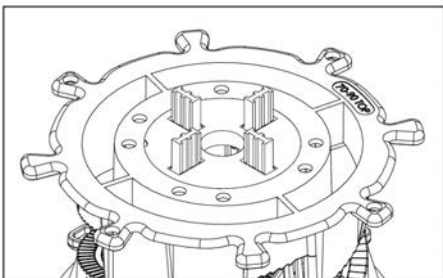
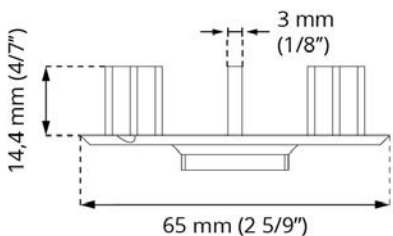
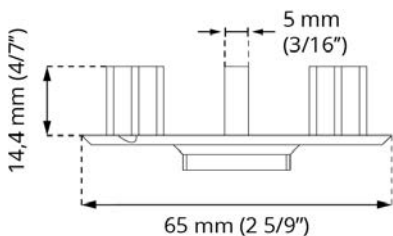
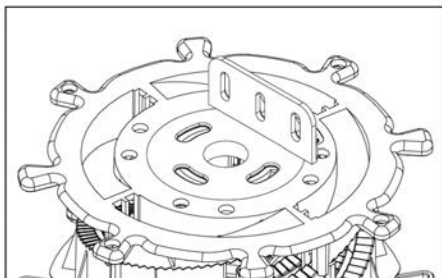
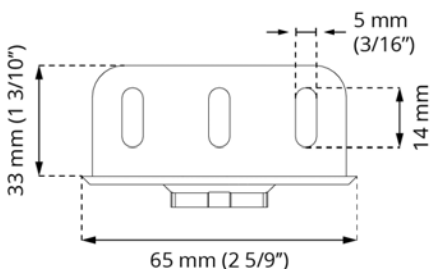
FOR TILES VERSION	FOR DECKING VERSION
SPIRAL 070-090 with Gap spacer disc 3 mm (1/8") (D3)	SPIRAL 070-090 with Gap spacer disc 5 mm (3/16") (D5)
	
	
	SPIRAL 070-090 with Joist adapter disc (DAD)
	
	

USAGE

The pedestals can be adjusted to tiles or pavers (using a gap spacer disk-D3, D5) or joists (using a joist adapter-AD or DAD). The pedestals have a modular construction consisting of two elements, with an additional spacer base element (DS60) attached for heights of 90 mm (3 1/2") and above, allowing for height increase. Adjustment is done every 1 mm (1/32") by rotating the upper element.

DATA LOGISTICS

Product	Type	Size	Quantity	Weight brutto
SPIRAL 070-090	Carton box	60 x 50 x 40 cm (23 2/3" x 19 2/3" x 15 3/4")	50 pcs.	17,8 kg (39.24 lbs)
	Pallet	120 x 100 x 220 cm (47 1/4" x 39 1/2" x 86")	1 000 pcs.	377,7 kg (832.69 lbs)

ADDITIONAL ACCESSORIES

Height coupler 60 mm (2 1/3") **DS60**, Self leveling head LE MAX 0-6% 20 mm (3/4") height **LE MAX**, Up to wall clip **DDPWAP**, Rubber shim **SH145**, Gap spacer disk 3 mm (1/8") **D3**, Gap spacer disk 5 mm (3/16") **D5**, Gap spacer 3 mm (1/8") **L3**, Gap spacer 5 mm (3/16") **L5**, Joist adapter disk **DAD**, Joist adapter **AD**, Side finishing closure tile **DDP CP**, SBR rubber pad SBR 200/3 mm (7 7/8" x 7 7/8" x 1/8") **SBR200/3**, SBR rubber pad SBR 200/8 mm (7 7/8" x 7 7/8" x 5/16") **SBR200/8**.

EXAMPLE OF SERIES SPIRAL APPLICATION

